

# Renaissance of torsion balance measurements in Hungary

Lajos VÖLGYESI<sup>1</sup>

Received 18-02-2015

## Abstract

In the 20<sup>th</sup> century, a large amount of torsion balance measurements have been carried out around the world. The measurements still provide a good opportunity to detect the lateral underground mass inhomogeneities and the geological fault structures using the so called edge effects in gravity gradients. Hitherto almost 60000 torsion balance measurements were made in Hungary mainly for geophysical purposes. Only the horizontal gradients were used for geophysical prospecting, the curvature gradients measured by torsion balance remained unused.

However, curvature gradients are very useful data in geodesy, using these gradients precise deflections of the vertical can be calculated by interpolation and using astrogeodetic determination of the geoid the fine structure of the geoid can be derived. In our test area a geoid with few centimeters accuracy was determined based on the curvature data.

Based on the horizontal and the curvature gradients of gravity the full Eötvös tensor (including the vertical gradients) can be derived by the 3D inversion method.

In our earlier research works additional new torsion balance measurements were necessary. Applying the new technical opportunities we reconstructed and modernized our older instruments, and additional torsion balance measurements have been made to study the linearity of gravity gradients.

## Keywords

gravity gradients; torsion balance; geoid; topographic reduction, full Eötvös tensor, linearity of gravity gradients

## Acknowledgement

This work was supported by OTKA project No. 76231.

<sup>1</sup>Department of Geodesy and Surveying  
 Faculty of Civil Engineering,  
 Budapest University of Technology and Economics  
 H-1521 Budapest, P.O.B. 91, Hungary (e-mail: [volgyesi@epito.bme.hu](mailto:volgyesi@epito.bme.hu))

## 1 Base principle of torsion balance

The Eötvös torsion balance was constructed and tested at the end of the 19<sup>th</sup> and the beginning of the 20<sup>th</sup> century by the Hungarian physicist Loránd Eötvös [1], [2]. Different types of torsion balances were produced, e.g. the main parts of the AUTERBAL (Automatic Eötvös-Rybár Balance) can be seen on the Fig. 1.

The torsion balance consists of a horizontal beam having the length  $2l$  with masses  $m$  on each ends suspended from a torsion wire. One of the two masses is affixed to one end of the horizontal beam, while the other mass is suspended below the other end of the beam, on a wire of length  $h$  – as it can be seen on Fig. 2. Horizontal component of gravity acting on the two masses causes a torque, and the horizontal beam is rotated until an equilibrium position with the restoring torque of the suspending torsion wire (having the torsion constant  $\tau$ ) is reached. In the equilibrium condition of torques the scale reading is  $n$ , while the scale reading of the torsion-free zero position of the beam would be  $n_0$  [3].

The base equation of the Eötvös torsion balance is:

$$n - n_0 = \frac{DK}{\tau} (W_{\Delta} \sin 2\alpha + 2W_{xy} \cos 2\alpha) + \frac{2lDhm}{\tau} (W_{xy} \cos \alpha - W_{zx} \sin \alpha) \quad (1)$$

where  $W_{zx}$  and  $W_{zy}$  are the horizontal gradients of gravity,  $W_{\Delta}$  and  $W_{xy}$  are the curvature gradients,  $K$  is the moment of inertia,  $\alpha$  is the azimuth of the beam and  $D$  is the optical distance (see on Fig. 2). The earlier type of instrument is the *Cavendish* torsion balance, in which the two masses are on the same height on the two ends of the beam [4]. This type of instrument is unable to measure the components of horizontal gradient  $W_{zx}$  and  $W_{zy}$ , because  $h = 0$  in Eq. (1).

Based on Eq. (1) there are five unknowns (the scale reading of the torsion-free zero position  $n_0$ , the horizontal gradients  $W_{zx}$ ,  $W_{zy}$  and the curvature gradients  $W_{\Delta}$ ,  $2W_{xy}$ ) at each measuring site, so the readings should be made in

five different azimuths. Usually two beam systems are mounted in one instrument at antiparallel position to each other, so there is a new unknown torsion-free zero position  $n'_0$  for the other beam system. Due to the additional unknown, minimum six measurements in three different azimuths (e.g.  $0^\circ$ ,  $120^\circ$ ,  $240^\circ$ ) are sufficient, but it is necessary to repeat the measurements in order to increase the accuracy.

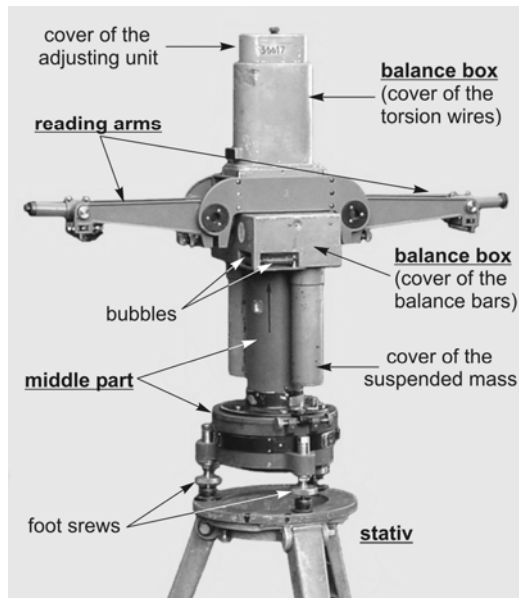

Fig. 1 Main parts of the AUTERBAL torsion balance

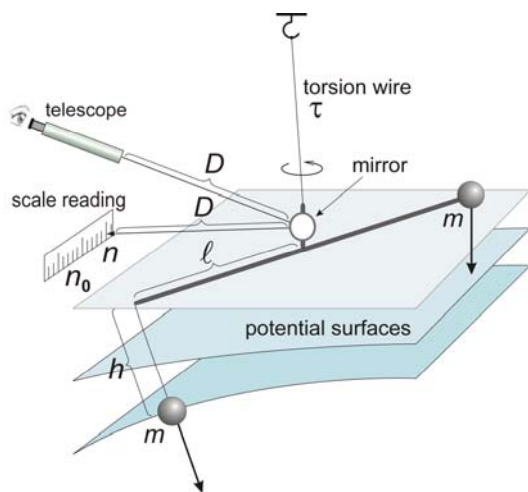

Fig. 2 Base principle of the torsion balance

## 2 Modernization of the torsion balances

Our earlier research required the observing of additional new torsion balance measurements. Applying the new technical opportunities we reconstructed and modernized our older instruments.

First using CCD sensors the scale readings were automatized [5]. Fixing the CCD cameras on the reading arms of the torsion balance can be seen on Fig. 3.

The main problem of torsion balance measurements was the long damping time however it is possible to sig-

nificantly reduce it. The damping curve can be precisely registered by CCD sensors as well as computerized data collection and evaluation. Based on the finite element solution of a fluid dynamics model and using the Navier-Stokes equations [6], the first part of this curve makes it possible to estimate the final position of the arm at rest. This study showed that these achievements may make it possible to cut down measurement time in each azimuth from 40 to 20 minutes to obtain accurate enough estimate of the home position of the balance (see on Fig. 4) [6].



Fig. 3 CCD camera on the reading arm of the torsion balance

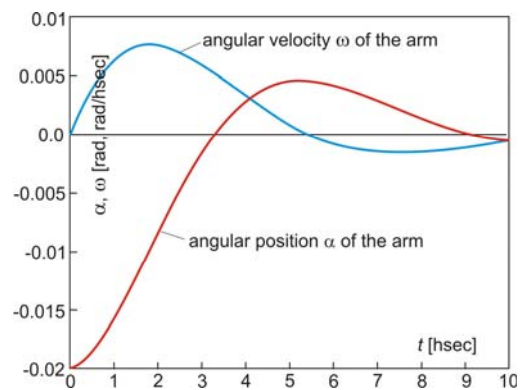

Fig. 4 Time-dependent angular position  $\alpha$  and angular velocity  $\omega$  of torsion balance arm (time  $t$  is measured in hectoseconds, 1 hs = 100 s)

## 3 Applications of the torsion balance measurements

The possible applications of torsion balance measurements are summarized in Fig. 5. On the left-hand side of the figure the elements of Eötvös-tensor are arranged to three groups. Horizontal gradients of gravity are marked by dark-grey shading area (these can be measured directly by torsion balance) while the curvature data are indicated with light-gray shading. The crossed element (the vertical gradient) on the right lower side of the Eötvös tensor, is not measurable directly by torsion balance. On the right-hand side of Fig. 5 the possible applications of torsion balance measurements are shortly summarized [5].

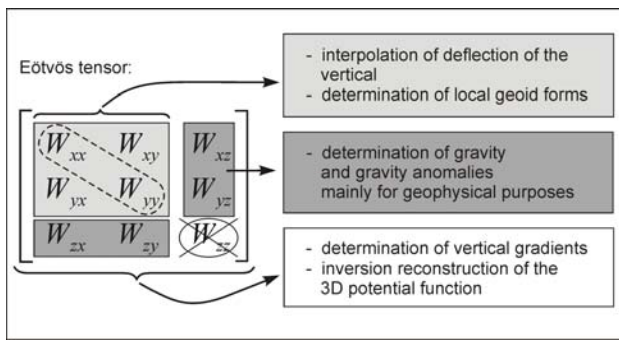

Fig. 5 Applications of the torsion balance measurements

If we know the observed values of the astrogeodetic deflection of the vertical at least in two points of an area, then values of the deflection of the vertical can be interpolated in every torsion balance points using the curvature gradients  $W_{\Delta}$  and  $W_{xy}$  [7], [8], [9]. From the interpolated deflection of the vertical values it is possible to determine the geoid heights applying the method of astrogeodetic determination [10], – so using torsion balance measurements we are able to determine the fine structure of the geoid.

Improvements of the new computational methods give new possibilities for the application of all elements of the Eötvös tensor. Besides the geodetic application of the curvature data the horizontal gradients of gravity measured by torsion balance can be used for geophysical and geodetic purposes too. Because the knowledge of the real gravity field of the Earth has a great importance in geophysics and physical geodesy, the possibility and the need for the usage of these horizontal gradients are important. Using these gradients combined with gravity or gravity anomalies the components of the local gravity field especially the low-degree components can be reproduced [11].

Knowledge of the vertical gradients is very important for different applications, but according to our researches, the real value of this vertical gradients significantly differ from the normal one [12]. Moreover this is the only component of the Eötvös-tensor which is not observable by torsion balance. Because the classical determination of the vertical gradients directly by gravimeters is a rather time consuming and expensive process, so another more simpler and less expensive method is necessary.

Torsion balance measurements give new possibility to determine vertical gradients by an interpolation method. Starting from curvature and horizontal gradients of gravity measured by torsion balance, the  $T_{zx}$ ,  $T_{zy}$  horizontal gradient anomalies and the  $T_{\Delta} = T_{yy} - T_{xx}$ ,  $2T_{xy}$  curvature anomalies of the disturbing potential  $T = W - U$  can be formed, and according to the Haalck method the vertical gradient anomaly  $T_{zz}$  can be determined from these values

[13], [14]. This method, similar to the astronomical leveling, generates differences of vertical gradients between at least three points measured by torsion balance. For this interpolation it is necessary to know the real (observed) value of vertical gradients in some points of the area.

Another new important application of torsion balance measurements is the 3D inversion reconstruction of gravity potential based on gravity gradients. This new inversion method gives opportunity to determine the function of gravity potential and their all first and all second derivatives (the components of gravity vector and the elements of the full Eötvös tensor – including the vertical gradient) [15]. Comparing the elements of the computed Eötvös tensor to the gravity gradients measured by torsion balance gives a good opportunity to control the inversion. Hereby an opportunity presents itself for the analytical determination of the potential surfaces which would be very important in physical geodesy.

Fig. 6 demonstrates the applicability of the torsion balance measurements for the determination of fine structure of the geoid. The Middle European part of the EGM2008 geoid model can be seen on the upper left part of the Figure. The isoline values of the geoid heights are in meters, and the distances between the isolines are 20 cm. On the right lower part of the figure the fine structure of the geoid computed from the torsion balance measurements can be seen on the enlarged area, distances between the isolines are 1 cm. The 248 torsion balance stations are marked by small dots. The average distances between torsion balance stations are 2-3 km, but shorter than 1 km on the northern part of the test area, and longer than 3 km on the lower left part of the area, depending on the linearity of gravity gradients (which mainly depends on the topography). 3 astrogeodetic points indicated with squares were used as initial (fixed) points and another 3 points indicated with triangles were used as control points on Fig. 6. Based on the given data in the control points standard deviation of the computed geoid heights is  $\pm 4$  cm.

In 1997 a quasigeoid solution HGTUB2007 was computed for Hungary using least-squares collocation technique by combining different gravity data sets, some astrogeodetic deflections, topographic information, and the GPS/leveling network data. As the evaluation of the solution has showed, the obtained accuracy was about 3-4 cm in terms of standard deviation of geoid height residuals [16]. Now a new solution is planned to compute by joint inversion appending all Hungarian torsion balance measurements to the previous input data.

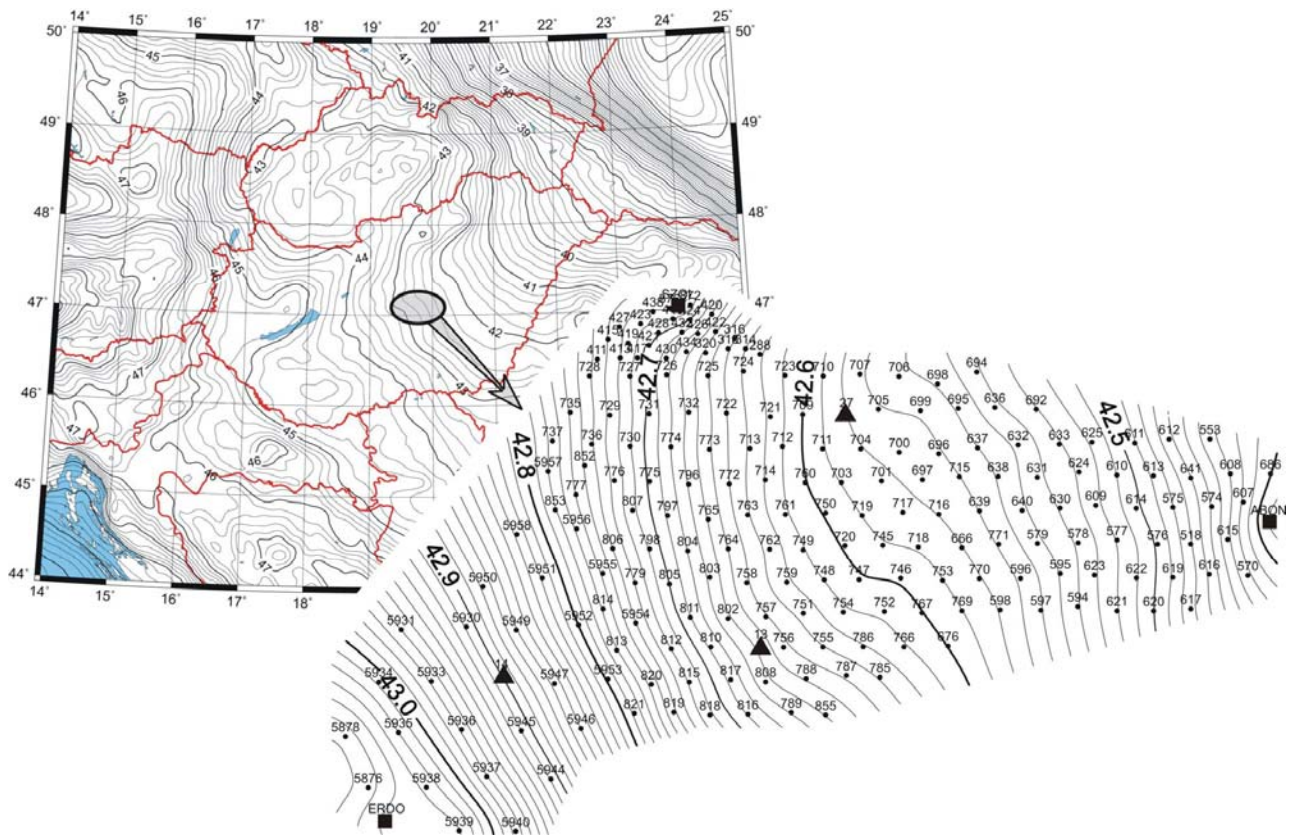

Fig. 6 Fine structure of the geoid forms in the middle part of Hungary based on torsion balance measurements

#### 4 New torsion balance measurements

From the beginning of the 20<sup>th</sup> century until the year 1967 almost 60000 torsion balance measurements were made in Hungary mainly for geophysical prospecting. The average distances between torsion balance stations vary between 500 m and 4 km, depending on the topography. Linear changing of the gravity gradients between the adjoining network points is an important demand for different interpolation methods (e.g. interpolation of the deflection of the vertical, geoid computations, and interpolation of the gravity values or the vertical gradients of gravity). During our researches a suspicion was aroused about the nonlinearity of the gravity gradients between the former neighboring torsion balance stations. The question is, whether the point density of these measurements is enough or not satisfy the linear changing requirements of gravity gradients? To study the linearity of gravity gradients, new torsion balance measurements were made both at the field and in a laboratory: one is at the Csepel Island [17], and the other in the Geodynamical Laboratory of Loránd Eötvös Geophysical Institute in the Mátyás cave. The uncommon huge changing of gravity gradients give the significance of the measurements in the cave, the values can reach up to 1000 E (1E = 1 Eötvös Unit =  $10^{-9}$   $1/s^2$ ) within a few meters. In the Fig. 7 the E54 torsion balance can be seen as ready for measurement on the Csepel Island in the summer of 2008.

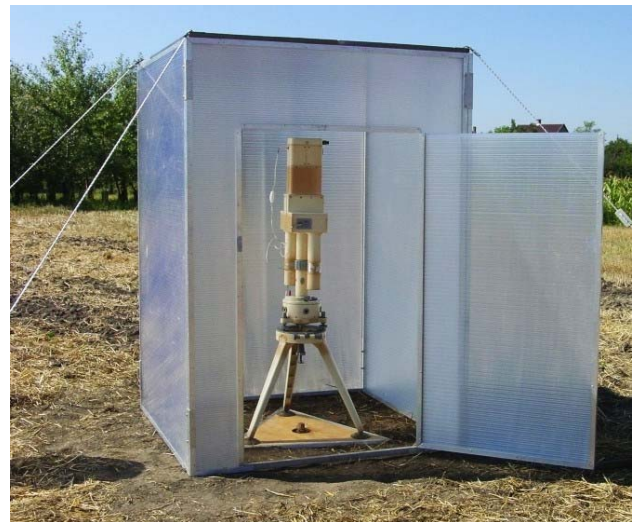

Fig. 7 Applications of the torsion balance measurements

For the linearity test 7 torsion balance points were selected from the older measurements made in 1950 at the southern part of the Csepel Island. This part of Hungary is nearly a flat area. The location of the selected points E220, E218, E238, E208, E206, E204, E207 can be seen on the lower part of Fig. 8. Both horizontal gradients  $W_{xz}$ ,  $W_{zy}$ , and curvature data  $W_{\Delta}$ ,  $W_{xy}$  measured by torsion balance and measurements corrected with topographic reduction were available at all points. To study the linearity of gravity gradients new torsion balance measurements were made with higher point density between the points E238

and E208. Location of the new points 3.a – 3.b – 3.c – 3.d – 3.e can be seen on the upper right part of Fig. 8, distances between them are 150 m. For the computation of the topographic reduction precise digital terrain model is necessary, so traditional leveling were carried out at 8 directions around each torsion balance stations between distances 0 - 100 m. Because our territory is nearly flat, computation of the topographic effect of masses beyond 100 m was not necessary [1]. Based on the digital terrain model topographic reduction of gravity gradients was computed by the known traditional method [18].

Curvature gradients marked by circles, measured by torsion balance in 1950, while these gradients corrected with topographic reduction marked by triangles can be seen on the upper part of Fig. 9. Distances between the points are depicted on the horizontal axes of the figures, the mean distance is about 1.5 km. The distances between

the new points are 150 m. The finer resolution pictures of the curvature gradients based on the new more detailed measurements can be seen on the lower part of Fig. 9.

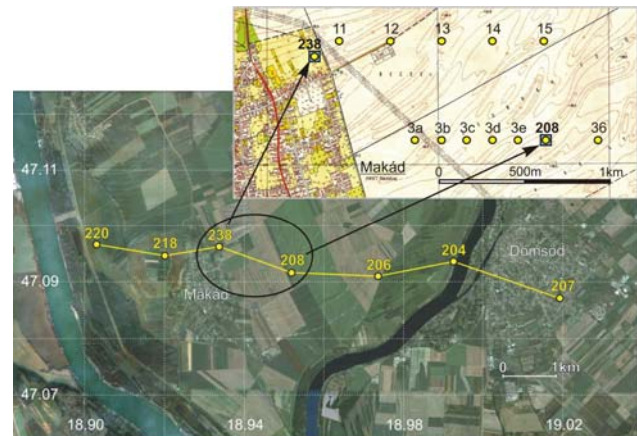

Fig. 8 Torsion balance points in the Csepel Island

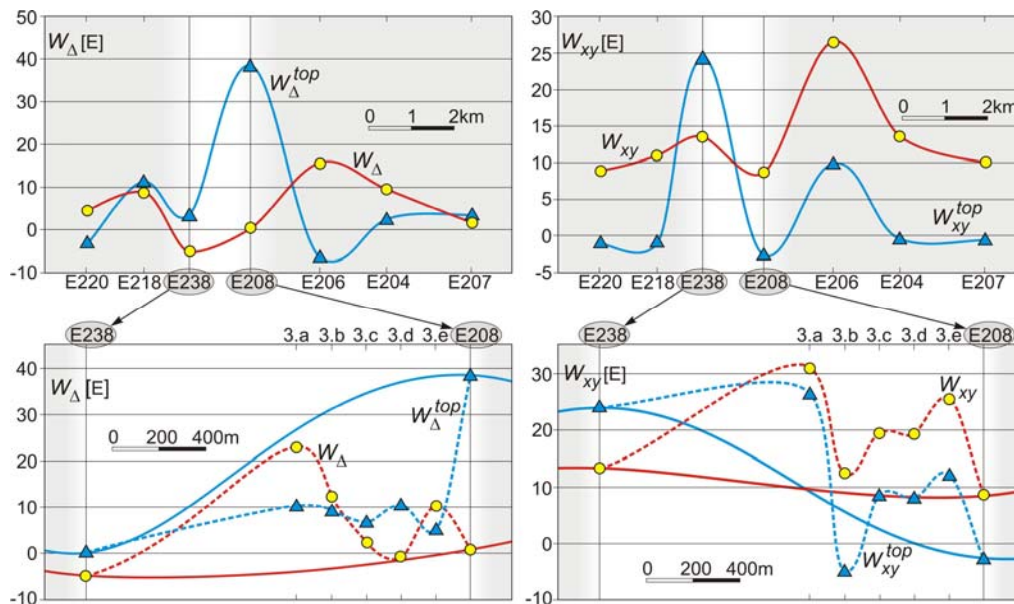

Fig. 9 Measured and corrected curvature data marked by circles and triangles respectively in the original and the refined network points

The value of  $R^2$  of the linear regression was applied to check and characterize the linearity of the torsion balance measurements [19]. The better the linear regression fits the data in comparison to the simple average, the closer the value of  $R^2$  is to one. The  $R^2$  values have been computed with various combinations for the torsion balance measurements and the results are show that decreasing the length of the measuring line improves the linearity of gravity gradients (because increases the values of  $R^2$ ). Decreasing distances between the torsion balance points from 1000–1500 m to 150–300 m result the improvement of linearity but not adequately in every cases [19].

The results of our investigations show that the linearity of the gravity gradients mainly depends on the point density of the torsion balance stations. It seems that the given point density of the earlier torsion balance stations may be not enough for some purposes. Moreover the problem could not be solved applying topographic reduction, because the mass density of the subsurface soil is

extremely diverse [20] due to the former Danube flood-plains in the test area. Further investigations would be necessary to determine the fine structure of the soil mass inhomogeneities near to the surface.

Possible solution for reaching the better linearity is to make new measurements between the former torsion balance stations. The necessary point density depends on the topography and the diversity of subsurface soil density, in some cases required distance between points may be shorter than 150 m.

## 5 Summary

The former and the new torsion balance measurements provide a good possibility to detect the lateral underground mass inhomogeneities and find the geological fault structures for the geologists and geophysicists. But the gravity gradients give very important information and knowledge for geodesists. Based on the gravity gradients

there is a possibility to determine the fine structure of the gravity and gravity anomalies, to interpolate deflection of the vertical values, to determine the fine structure of the geoid forms and it is possible to reconstruct the potential field of gravity applying the 3D algorithm of inversion method. To reach the linearity of gravity gradients between the former torsion balance stations new measurements need to be made, the number of the new measurements (densification of the former network) mainly depends on the topography and the subsoil mass inhomogeneities.

## Reference list

- [1] Selényi, P. "Roland Eötvös Gesammelte Arbeiten." *Akadémiai Kiadó*, Budapest. 1953.
- [2] Szabó, Z. "History of the torsion balance." *Magyar Geofizika*. **40**(1), pp. 26-38, 1999. (In Hungarian)
- [3] Völgyesi, L. "Geodetic applications of torsion balance measurements in Hungary." *Reports on Geodesy*, Warsaw University of Technology, **57**(2), pp. 203-212. 2001.
- [4] Völgyesi, L. "Geophysics." Tankönyvkiadó, Budapest. (In Hungarian) 2002.
- [5] Völgyesi, L., Ultman, Z. "Reconstruction of a torsion balance, and the results of the test measurements." In: S. Kenyon, M.C.Pacino, U Marti (Eds.) *Geodesy for Planet Earth, Buenos Aires, Argentina*. IAG Symposia, Vol. 136, Springer-Verlag; Berlin, Heidelberg, pp. 281-289. 2012.
- [6] Tóth, Gy., Völgyesi, L., Laky, S. "Reducing the measurement time of the torsion balance." *Earth on the Edge: Science for a Sustainable Planet* (Eds: Rizos, C., Willis, P.) IAG Symposia Vol. 139, Springer-Verlag; Berlin, Heidelberg. pp. 341-347. 2014.
- [7] Badekas, J., Mueller, I. I. "Interpolation of deflections from horizontal gravity gradients." *Reports of the Department of Geodetic Science*, **98**, The Ohio State University. 1967.
- [8] Völgyesi, L. "Deflections of the vertical and geoid heights from gravity gradients." *Acta Geodaetica et Geophysica Hungarica*, **40**(2), pp. 147-159. 2005.
- [9] Biró, P., Ádám, J., Völgyesi, L., Tóth, Gy. "Geodesy, theory and practice." HM Zrínyi Térképészeti és Kommunikációs Szolgáltató Nonprofit Kft. *Kiadó*, Budapest, ISBN 978-963-257-248-2. (In Hungarian) 2013.
- [10] Völgyesi, L. "Local geoid determinations based on gravity gradients." *Acta Geodaetica et Geophysica Hung.* **36**(2), pp. 153-162. 2001.
- [11] Völgyesi, L., Tóth, Gy., Csapó, G. "Determination of gravity anomalies from torsion balance measurements." IAG Symposia Vol. 129, *Gravity, Geoid and Space Missions*, C. Jekeli, L. Bastos, J. Fernandes (Eds.), Springer, pp. 292-297. 2005.
- [12] Csapó, G., Völgyesi, L. "New measurements for the determination of local vertical gradients." *Reports on Geodesy*, Warsaw University of Technology, **69**(2), pp. 303-308. 2004.
- [13] Haalck, H. "Die vollständige Berechnung örtlicher gravimetrischer Störfelder aus Drehwaagemessungen." *Veröffentlichungen des Geodätischen Institutes Potsdam*, Nr. 4, Potsdam. 1950.
- [14] Tóth, Gy., Völgyesi, L., Csapó, G. "Determination of vertical gradients from torsion balance measurements." IAG Symposia Vol. 129, *Gravity, Geoid and Space Missions*, C. Jekeli, L. Bastos, J. Fernandes (Eds.), Springer, pp. 292-297. 2005.
- [15] Dobróka, M., Völgyesi, L. "Inversion reconstruction of gravity potential based on gravity gradients." *Mathematical Geosciences*, **40**(3), pp. 299-311. 2008.
- [16] Tóth, Gy. "New combined geoid solution HGTUB2007 for Hungary." In: *Observing our Changing Earth*. Ser. IAG Symposia, Sideris, G Michael ed., 133, pp. 405-412. 2009.
- [17] Csapó, G., Laky, S., Égető, Cs., Ultmann, Z., Tóth, Gy., Völgyesi, L. "Test measurements by Eötvös-torsion balance and gravimeters." *Periodica Polytechnica Civil Eng.* **53**(2), pp. 75-80. 2009. Doi:10.3311/pp.ci.2009/2.03.
- [18] Torge, W. "Gravimetry" Walter de Gruyter, Berlin – New York. 1989
- [19] Völgyesi, L., Ultmann, Z. "High-Resolution Measurements of Non-Linear Spatial Distribution of Gravity Gradients in Hungary." *Earth on the Edge: Science for a Sustainable Planet* (Eds: C. Rizos, P. Willis) IAG Symposia Vol. 139, Springer-Verlag; Berlin, Heidelberg, pp. 435-444. 2014.
- [20] Ultmann, Z. "Torsion balance measurements and its geodetic applications." Ph.D Thesis, Budapest University of Technology and Economics. Budapest. (In Hungarian) 2013.

\* \* \*

L. Völgyesi (2015): Renaissance of the torsion balance measurements in Hungary. *Periodica Polytechnica Civil Engineering*, Vol. 59, No. 4. pp. 459-464, DOI: 10.3311/Ppci.7990.

Dr. Lajos VÖLGYESI, Department of Geodesy and Surveying, Budapest University of Technology and Economics, H-1521 Budapest, Hungary, Műegyetem rkp. 3.  
 Web: <http://agt.bme.hu/volgyesi> E-mail: [volgyesi@eik.bme.hu](mailto:volgyesi@eik.bme.hu)